

SCHLEIFDORNE

GRINDING WHEEL HOLDERS

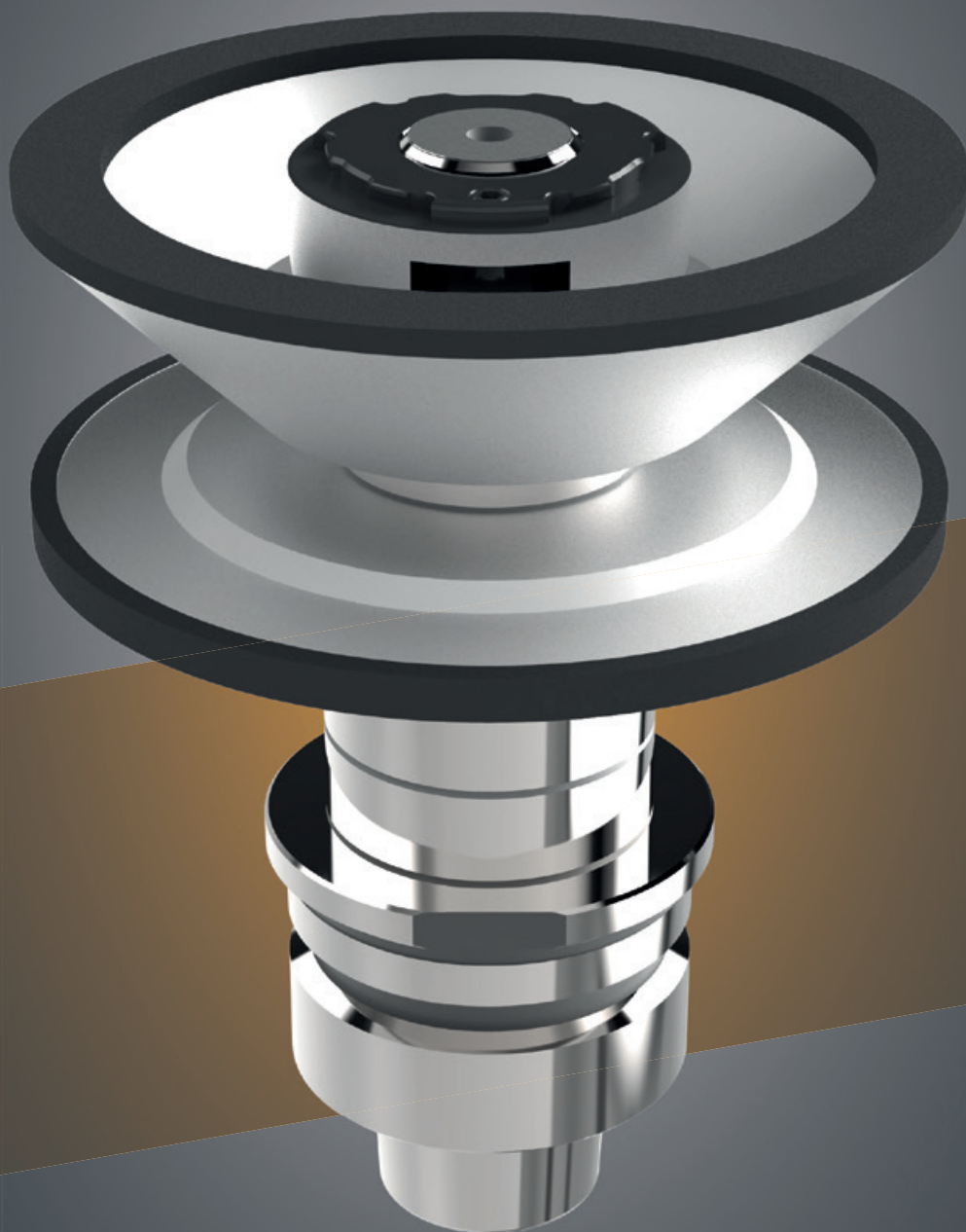

Anca · Haas · Hawema · Deckel/ISOG · Saacke · Schneeberger
Schütte · Rollomatic · Reinecker · Walter · BT30/Fanuc · TTB

INHALTSVERZEICHNIS | INDEX

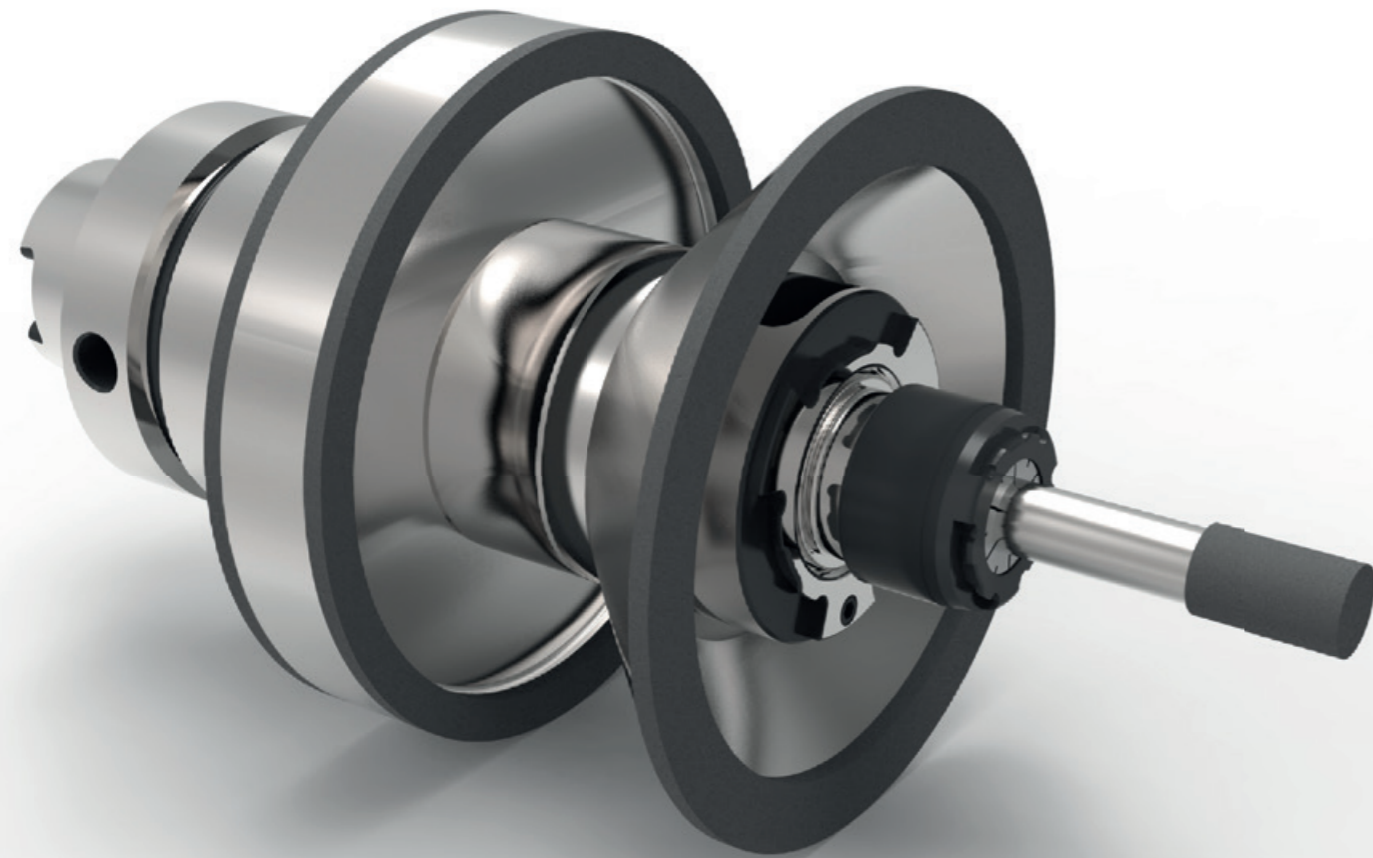

Produkt Product	Seite Page
ANCA Schleifdorne ANCA grinding wheel holders	4-9
ANCA Schleifdornadapter ANCA grinding wheel holder-adapter	10
ANCA BT40 mit Plananlage ANCA BT40 Dual contact	11
BT/Fanuc Schleifdorne BT/Fanuc Grinding wheel holders	12-13
Deckel/ISOG Schleifdorne Deckel/ISOG Grinding wheel holders	14-15
HAAS Schleifdorne HAAS Grinding wheel holders	16-17
Hawema Haller Schleifdorne Hawema Haller Grinding wheel holders	18-19
Reinecker Schleifdorne Reinecker Grinding wheel holders	20
Rollomatic Schleifdorne Rollomatic Grinding wheel holders	21
Saacke/Vollmer Schleifdorne Saacke Grinding wheel holders	22-23
Schneeberger Schleifdorne Schneeberger Grinding wheel holders	24-26
Zeta Sicherheitsspannscheiben Information Zeta safety clamping nuts informations	27
Schütte Schleifdorne Schütte Grinding wheel holders	28-29
TTB Schleifdorne TTB Grinding wheel holders	30
Walter Schleifdorne Walter Grinding wheel holders	31-33
Allgemeine Geschäftsbedingungen Conditions of sale	34
Notizen Notes	35

ANCA

Schleifdorne | Grinding wheel holder

HSK 40-F / 50-F / automatisches Spannen | automatic tool clamping



SCHLEIFDORN MIT HOHLSCHAFTKEGEL HSK 40-F UND HSK 50-F

gehärtet und feingewuchtet, für automatischen Werkzeugwechsel

GRINDING WHEEL HOLDER HSK 40-F AND HSK 50-F

hardened and balanced, for automatic tool clamping

Standardmäßig mit dem patentierten **ZETA-Sicherheitssystem** ausgestattet.

Includes the patented Zeta-safety clamping system.

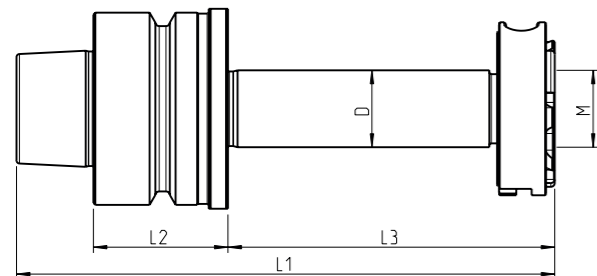

HSK	D	L1	L2	L3	M	Artikelnummer Part number	
HSK 40-F	20	104	33	55	M20x1,5	SDANC40F03305520	
	20	124	33	75	M20x1,5	SDANC40F03307520	
	20	134	33	85	M20x1,5	SDANC40F03308520	
	20	144	33	95	M20x1,5	SDANC40F03309520	
	31,75	104	33	55	M30x1,5	SDANC40F03305531.75	
	31,75	124	33	75	M30x1,5	SDANC40F03307531.75	
	31,75	134	33	85	M30x1,5	SDANC40F03308531.75	
	31,75	144	33	95	M30x1,5	SDANC40F03309531.75	
	32	104	33	55	M30x1,5	SDANC40F03305532	
	32	124	33	75	M30x1,5	SDANC40F03307532	
	32	134	33	85	M30x1,5	SDANC40F03308532	
	32	144	33	95	M30x1,5	SDANC40F03309532	
HSK 50-F	20	90	35	35	M20x1,5	SDANC50F03503520	
	20	100	35	45	M20x1,5	SDANC50F03504520	
	20	110	35	55	M20x1,5	SDANC50F03505520	
	20	127	35	72	M20x1,5	SDANC50F03507220	
	20	140	35	85	M20x1,5	SDANC50F03508520	
	20	150	35	95	M20x1,5	SDANC50F03509520	
		31,75	90	35	35	M30x1,5	SDANC50F03503531.75
		31,75	100	35	45	M30x1,5	SDANC50F03504531.75
		31,75	110	35	55	M30x1,5	SDANC50F03505531.75
		31,75	127	35	72	M30x1,5	SDANC50F03507231.75
		31,75	140	35	85	M30x1,5	SDANC50F03508531.75
		31,75	150	35	95	M30x1,5	SDANC50F03509531.75
	32	110	35	55	M30x1,5	SDANC50F03505532	
	32	127	35	72	M30x1,5	SDANC50F03507232	
	32	140	35	85	M30x1,5	SDANC50F03508532	
	32	150	35	95	M30x1,5	SDANC50F03509532	

Lieferumfang: Spannscheibe und dazugehöriger Ringsatz

Delivery conditions: including nut and spacer set

ANCA

Schleifdorne | Grinding wheel holder

HSK 40-F / manuelles Spannen | manual tool clamping



SCHLEIFDORN MIT HOHLSCHAFTKEGEL HSK 40-F

gehärtet und feingewuchtet, für manuellen Werkzeugwechsel

GRINDING WHEEL HOLDER HSK 40-F

hardened and balanced, for manual tool clamping

Standardmäßig mit dem patentierten **ZETA-Sicherheitssystem** ausgestattet.

Includes the patented Zeta-safety clamping system.

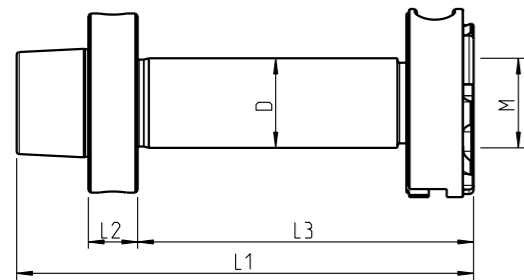

HSK	D	L1	L2	L3	M	Artikelnummer Part number
HSK 40-F	20	82	11	55	M20x1,5	SDANC40F01105520
	20	102	11	75	M20x1,5	SDANC40F01107520
	31.75	102	11	75	M30x1,5	SDANC40F01107531.75
	31.75	122	11	95	M30x1,5	SDANC40F01109531.75

Lieferumfang: Spannscheibe und dazugehöriger Ringsatz

Delivery conditions: including nut and spacer set

ANCA

Schleifdorne | Grinding wheel holder

HSK 40-F / manuelles Spannen | manual tool clamping



SCHLEIFDORN MIT HOHLSCHAFTKEGEL HSK 40-F

gehärtet und feingewuchtet, für manuellen Werkzeugwechsel

GRINDING WHEEL HOLDER HSK 40-F

hardened and balanced, for manual tool clamping

Standardmäßig mit dem patentierten **ZETA-Sicherheitssystem** ausgestattet.

Includes the patented Zeta-safety clamping system.

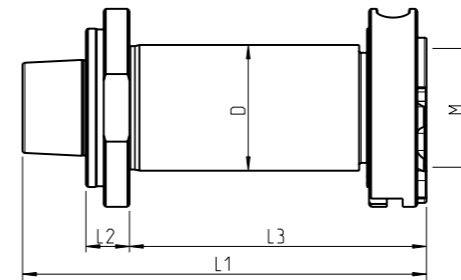

HSK	D	L1	L2	L3	M	Artikelnummer Part number
HSK 40-F	31.75	102	11	75	M30x1,5	SDANC40F01107531.75B
	31.75	122	11	95	M30x1,5	SDANC40F01109531.75B
	32	102	11	75	M30x1,5	SDANC40F01107532B
	32	122	11	95	M30x1,5	SDANC40F01109532B

Lieferumfang: Spannscheibe und dazugehöriger Ringsatz

Delivery conditions: including nut and spacer set

ANCA

Kombischleifdorne / Combined grinding wheel holder

HSK 40-F / 50-F / autom. Spannen / auto. tool clamping



KOMBISCHLEIFDORN MIT HOHLSCHAFTKEGEL HSK 40-F UND HSK 50-F

gehärtet und feingewuchtet, für doppelt geschlitzte Spannzangen, für automatischen Werkzeugwechsel

COMBINATED GRINDING WHEEL HOLDER HSK 40-F AND HSK 50-F

hardened and balanced, for double slotted collets, for automatic tool clamping

Standardmäßig mit dem patentierten ZETA-Sicherheitssystem ausgestattet.

Includes the patented Zeta-safety clamping system.

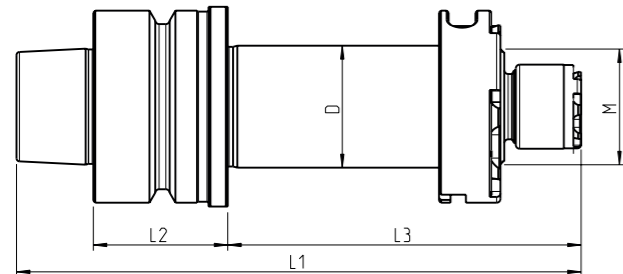

HSK	D	L1	L2	L3	M	Artikelnummer Part number
HSK 40-F	20	134	33	85	M20x1,0	SDANC40F0330852016ERM
	31.75	134	33	85	M30x1,5	SDANC40F03308531.7516ERM
HSK 50-F	20	140	35	85	M20x1,0	SDANC50F0350852016ERM
	31.75	140	35	85	M30x1,5	SDANC50F03508531.7516ERM

Lieferumfang: Spannscheibe und dazugehöriger Ringsatz

Delivery conditions: including nut and spacer set

ANCA

TGX-Schleifdorn / TGX-Grinding wheel holder

HSK 50-E / autom. Spannen / automatic tool clamping



TGX-SCHLEIFDORN MIT HOHLSCHAFTKEGEL HSK 50-E

gehärtet und feingewuchtet, für automatischen Werkzeugwechsel

TGX-GRINDING WHEEL HOLDER HSK 50-E

hardened and balanced, for automatic tool clamping

Standardmäßig mit dem patentierten ZETA-Sicherheitssystem ausgestattet.

Includes the patented Zeta-safety clamping system.

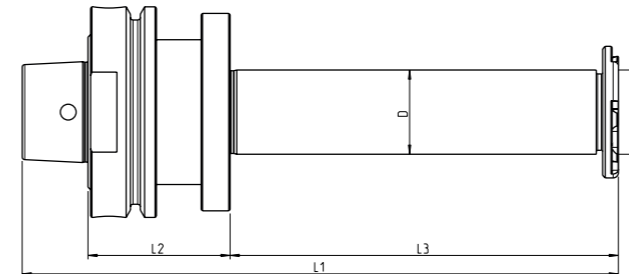

HSK	D	L1	L2	L3	M	Artikelnummer Part number
HSK 50-E	32	226	54	147	M32x1,0	SDANC50E05414732
	50,8	254	54	145	M40x1,0	SDANC50E05417550.8

Lieferumfang: Spannscheibe und dazugehöriger Ringsatz

Delivery conditions: including nut and spacer set

ANCA

MG7/RGX-SchleifdornADAPTER / MG7/RGX-adapter

Innenkegel 30 | Internal taper 30

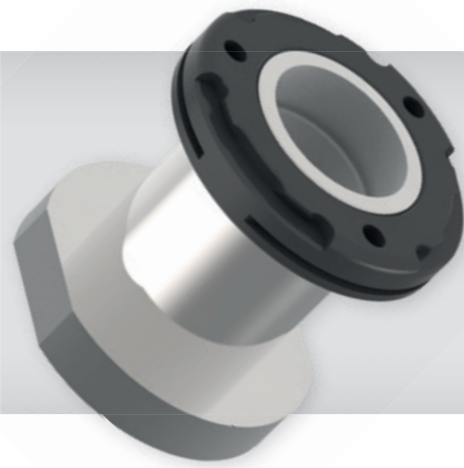

MG7/RGX-SCHLEIFDORNADAPTER

gehärtet und feingewuchtet

MG7/RGX-GRINDING WHEEL HOLDER ADAPTER

hardened and balanced

Standardmäßig mit dem patentierten ZETA-Sicherheitssystem ausgestattet.

Includes the patented Zeta-safety clamping system.

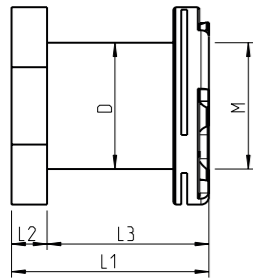

	D	L1	L2	L3	M	Artikelnummer Part number
Adapter Anca	20	78	37	41	M20x1,5	SDANCRGX4120
	32	50	9	41	M32x1,5	SDANCRGX4132

Lieferumfang: Spannscheibe und dazugehöriger Ringsatz

Delivery conditions: including nut and spacer set

ANCA

TX7-BT40 mit Plananlage / TX7-BT40 dual contact

ähnlich BT40 | similar BT40



BT40 MIT PLANANLAGE

gehärtet und feingewuchtet

BT40 DUAL CONTACT

hardened and balanced

Standardmäßig mit dem patentierten ZETA-Sicherheitssystem ausgestattet.

Includes the patented Zeta-safety clamping system.

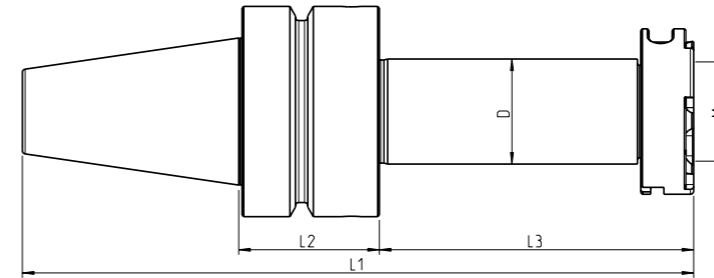

HSK	D	L1	L2	L3	M	Artikelnummer Part number
PBT40	31,75	183	42,5	75	M20x1,5	SD40PBT04207531,75
	31,75	203	42,5	95	M30x1,5	SD40PBT04209531.75

Lieferumfang: Spannscheibe und dazugehöriger Ringsatz

Delivery conditions: including nut and spacer set

BT / FANUC

Schleifdorne / Grinding wheel holder

BT30 / automatisches Spannen / automatic tool clamping

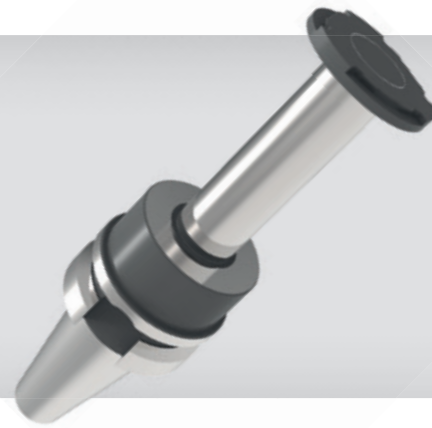

BT/FANUC-SCHLEIFDORN MIT BT30-KEGEL

gehärtet und feingewuchtet, für automatischen Werkzeugwechsel

BT/FANUC-GRINDING WHEEL HOLDER - BT30

hardened and balanced, for automatic tool clamping

Standardmäßig mit dem patentierten **ZETA-Sicherheitssystem** ausgestattet.

Includes the patented Zeta-safety clamping system.

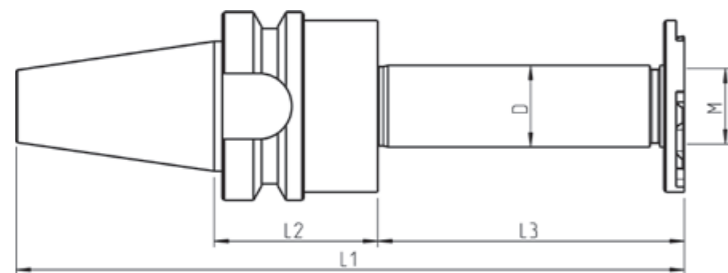

Typ / Type	D	L1	L2	L3	M	Artikelnummer Part number
BT/Fanuc	20	148,4	45	55	M20x1,0	SD30BT04505520
	20	173,4	45	80	M20x1,0	SD30BT04508020

Lieferumfang: Spannscheibe und dazugehöriger Ringsatz

Delivery conditions: including nut and spacer set

BT / FANUC

Kombischleifdorne / Combined grinding wheel holder

BT30 / automatisches Spannen / automatic tool clamping



BT/FANUC-KOMBISCHLEIFDORN MIT BT30-KEGEL

gehärtet und feingewuchtet, für automatischen Werkzeugwechsel

BT/FANUC-COMBI GRINDING WHEEL HOLDER - BT30

hardened and balanced, for automatic tool clamping

Standardmäßig mit dem patentierten **ZETA-Sicherheitssystem** ausgestattet.

Includes the patented Zeta-safety clamping system.

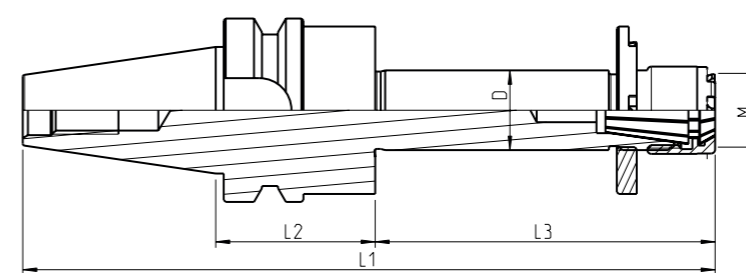

Typ / Type	D	L1	L2	L3	M	Artikelnummer Part number
BT/Fanuc	20	137	40	50,5	M20x1,0	SPZ-SD30BT04005520
	20	164	40	85,5	M20x1,0	SPZ-SD30BT04008520

Lieferumfang: Spannscheibe und dazugehöriger Ringsatz

Delivery conditions: including nut and spacer set

DECKEL / ISOG

Schleifdorne / Grinding wheel holder

HSK 50-F / automatisches Spannen / automatic tool clamping

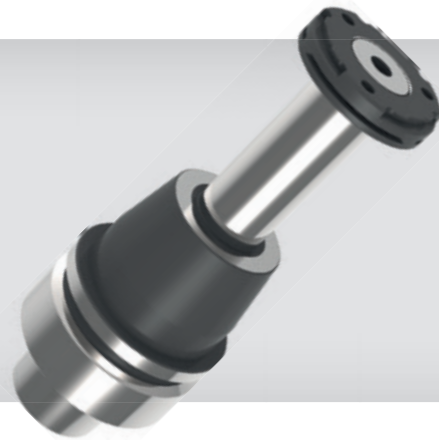

DECKEL/ISOG-SCHLEIFDORN MIT HOHLSCHAFTKEGEL HSK 50-F

gehärtet und feingewuchtet, für automatischen Werkzeugwechsel

DECKEL/ISOG-GRINDING WHEEL HOLDER HSK 50-F

hardened and balanced, for automatic tool clamping

Standardmäßig mit dem patentierten **ZETA-Sicherheitssystem** ausgestattet.

Includes the patented Zeta-safety clamping system.

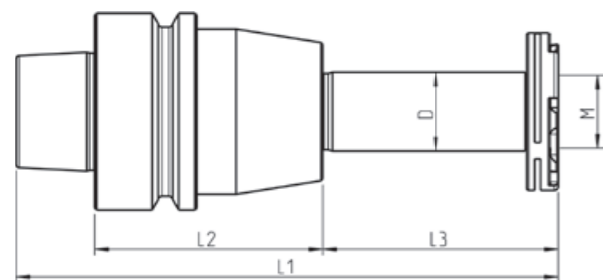

Typ / Type	D	L1	L2	L3	M	Artikelnummer Part number
Deckel/Isog	20	106	36	50	M20x1,0	SDDECK50F3605020
	20	138	58	60	M20x1,0	SDDECK50F5806020
	20	168	58	90	M20x1,0	SDDECK50F5809020
	20	168	88	60	M20x1,0	SDDECK50F8806020

Lieferumfang: Spannscheibe und dazugehöriger Ringsatz

Delivery conditions: including nut and spacer set

DECKEL / ISOG

Kombischleifdorne / Combined grinding wheel holder

HSK 50-F / automatisches Spannen / automatic tool clamping



DECKEL/ISOG-KOBMISCHLEIFDORN MIT HOHLSCHAFTKEGEL HSK 50-F

gehärtet und feingewuchtet, für automatischen Werkzeugwechsel

DECKEL/ISOG-COMBI GRINDING WHEEL HOLDER HSK 50F

hardened and balanced, for automatic tool clamping

Standardmäßig mit dem patentierten **ZETA-Sicherheitssystem** ausgestattet.

Includes the patented Zeta-safety clamping system.

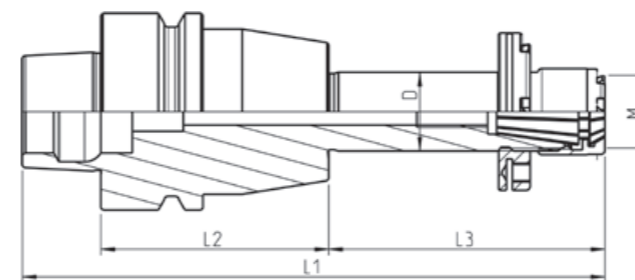

Typ / Type	D	L1	L2	L3	M	Artikelnummer Part number
Deckel/Isog	20	168	58	60	M20x1,0	SD-SPZDECK50F5806020

Lieferumfang: Spannscheibe und dazugehöriger Ringsatz

Delivery conditions: including nut and spacer set

HAAS

Schleifdorne / Grinding wheel holder

HSK 50-E mit Zugriffsbohrung / automatisches Spannen | automatic tool clamping

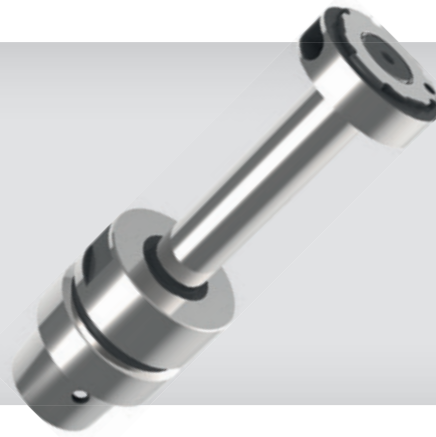

HAAS-SCHLEIFDORN MIT HOHLSCHAFTKEGEL HSK 50-E

gehärtet und feingewuchtet, für automatischen Werkzeugwechsel

HAAS-GRINDING WHEEL HOLDER HSK 50-E

hardened and balanced, for automatic tool clamping

Standardmäßig mit dem patentierten **ZETA-Sicherheitssystem** ausgestattet.

Includes the patented Zeta-safety clamping system.

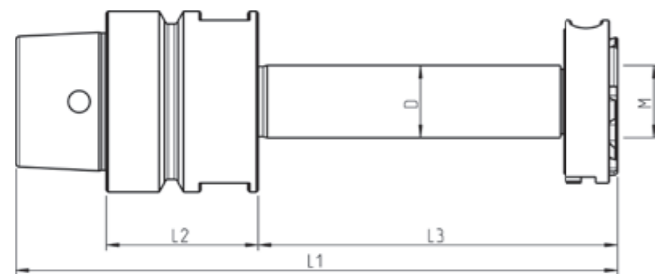

Typ / Type	D	L1	L2	L3	M	Artikelnummer Part number
Haas	20	107	42	40	M20x1,0	SDHAA50E04204020
	20	127	42	60	M20x1,0	SDHAA50E04206020
	20	167	42	100	M20x1,0	SDHAA50E04210020

Lieferumfang: Spannscheibe und dazugehöriger Ringsatz

Delivery conditions: including nut and spacer set

HAAS

Kombischleifdorne / Combined grinding wheel holder

HSK 50E mit Zugriffsbohrung / automatisches Spannen | automatic tool clamping

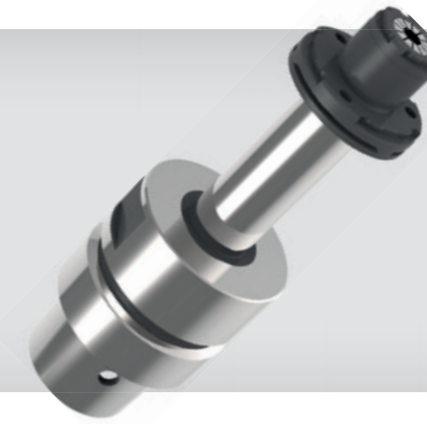

HAAS KOMBI-SCHLEIFDORN MIT HOHLSCHAFTKEGEL HSK 50-E

gehärtet und feingewuchtet, für automatischen Werkzeugwechsel

HAAS COMBI-GRINDING WHEEL HOLDER HSK 50-E

hardened and balanced, for automatic tool clamping

Standardmäßig mit dem patentierten **ZETA-Sicherheitssystem** ausgestattet.

Includes the patented Zeta-safety clamping system.

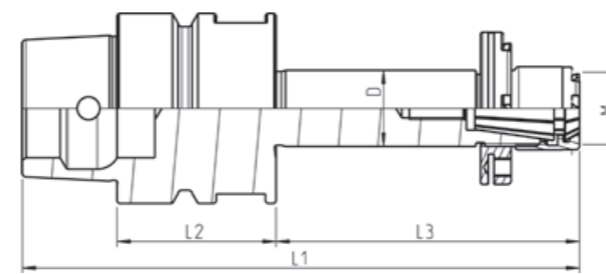

Typ / Type	D	L1	L2	L3	M	Artikelnummer Part number
Haas	20	147,5	42	80	M30x1,0	SD-SPZHAA50E04208020

Lieferumfang: Spannscheibe und dazugehöriger Ringsatz

Delivery conditions: including nut and spacer set

HAWEMA

Schleifdorne / Grinding wheel holder

HSK 50-A / automatisches Spannen / automatic tool clamping

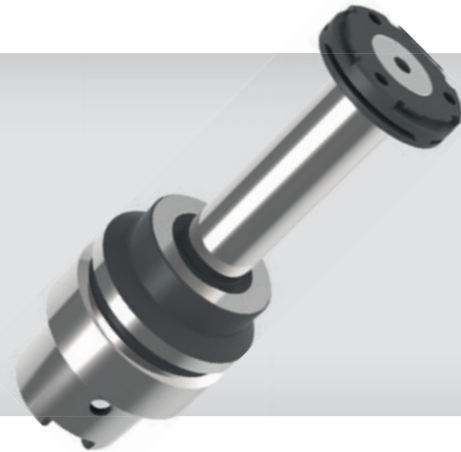

HAWEMA-SCHLEIFDORN MIT HOHLSCHAFTKEGEL HSK 50-A

gehärtet und feingewuchtet, für automatischen Werkzeugwechsel

HAWEMA-GRINDING WHEEL HOLDER HSK 50-A

hardened and balanced, for double slotted collets, for automatic tool clamping

Standardmäßig mit dem patentierten **ZETA-Sicherheitssystem** ausgestattet.

Includes the patented Zeta-safety clamping system.

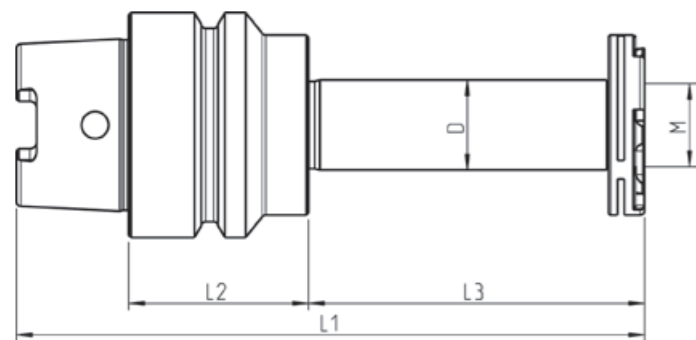

Typ / Type	D	L1	L2	L3	M	Artikelnummer Part number
Hawema	20	115	40	50	M20x1,0	SDHAW50A04005020
	20	140	40	75	M20x1,0	SDHAW50A04007520
	20	150	40	85	M20x1,0	SDHAW50A04008520
	20	160	40	95	M20x1,0	SDHAW50A04009520
	20	175	40	110	M20x1,0	SDHAW50A04011020

Lieferumfang: Spannscheibe und dazugehöriger Ringsatz

Delivery conditions: including nut and spacer set

HAWEMA

Kombischleifdorne / Combined grinding wheel holder

HSK 50-A / automatisches Spannen / automatic tool clamping



HAWEMA-KOMBISCHLEIFDORN MIT HOHLSCHAFTKEGEL HSK 50-A

gehärtet und feingewuchtet, für automatischen Werkzeugwechsel

HAWEMA-COMBI GRINDING WHEEL HOLDER HSK 50-A

hardened and balanced, for automatic tool clamping

Standardmäßig mit dem patentierten **ZETA-Sicherheitssystem** ausgestattet.

Includes the patented Zeta-safety clamping system.

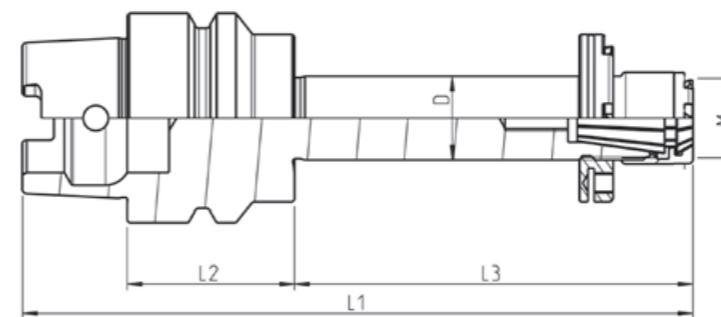

Typ / Type	D	L1	L2	L3	M	Artikelnummer Part number
Hawema	20	130	40	65	M20x1,0	SD-SPZHW50A04006520

Lieferumfang: Spannscheibe und dazugehöriger Ringsatz

Delivery conditions: including nut and spacer set

REINECKER

Schleifdorne | Grinding wheel holder

HSK 50-E mit Zugriffsbohrung / automatisches Spannen | automatic tool clamping



REINECKER-SCHLEIFDORN MIT HOHLSCHAFTKEGEL HSK 50E

gehärtet und feingewuchtet, für automatischen Werkzeugwechsel

REINECKER-GRINDING WHEEL HOLDER HSK 50E

hardened and balanced, for automatic tool clamping

Standardmäßig mit dem patentierten **ZETA-Sicherheitssystem** ausgestattet.

Includes the patented Zeta-safety clamping system.

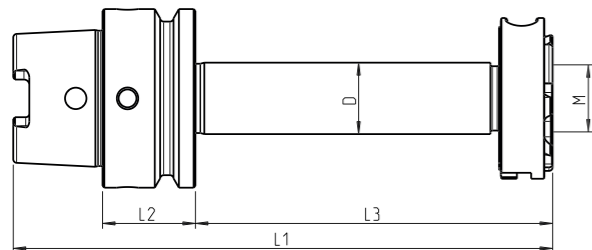

Typ / Type	D	L1	L2	L3	M	Artikelnummer Part number
Reinecker	20	95	26	49	M20x1,0	SDREIN50E026049020
	20	115	26	81	M30x1,5	SDREIN50E026081020
	31,75	95	26	49	M20x1,0	SDREIN50E026049031.75
	31,75	115	26	81	M30x1,5	SDREIN50E026081031.75

Lieferumfang: Spannscheibe und dazugehöriger Ringsatz

Delivery conditions: including nut and spacer set

ROLLOMATIC

Schleifdorne | Grinding wheel holder

HSK 50-E / automatisches Spannen | automatic tool clamping



ROLLOMATIC-SCHLEIFDORN MIT HOHLSCHAFTKEGEL HSK 50-E

gehärtet und feingewuchtet, für automatischen Werkzeugwechsel

ROLLOMATIC-GRINDING WHEEL HOLDER HSK 50-E

hardened and balanced, for automatic tool clamping

Standardmäßig mit dem patentierten **ZETA-Sicherheitssystem** ausgestattet.

Includes the patented Zeta-safety clamping system.

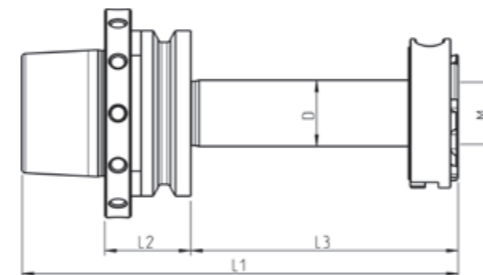

Typ / Type	D	L1	L2	L3	M	Artikelnummer Part number
Rollomatic	20	95	26	49	M20x1,0	SDROL50E026049020
	20	115	26	81	M30x1,5	SDROL50E026081020
	31,75	95	26	49	M20x1,0	SDROL50E026049031.75
	31,75	115	26	81	M30x1,5	SDROL50E026081031.75

Lieferumfang: Spannscheibe und dazugehöriger Ringsatz

Delivery conditions: including nut and spacer set

SAACKE / VOLLMER

Schleifdorne / Grinding wheel holder

HSK 50-A / automatisches Spannen / automatic tool clamping

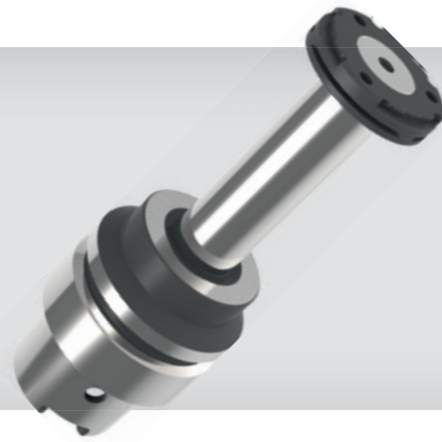

SAACKE/VOLLMER-SCHLEIFDORN MIT HOHLSCHAFTKEGEL HSK 50-A

gehärtet und feingewuchtet, für automatischen Werkzeugwechsel

SAACKE/VOLLMER-GRINDING WHEEL HOLDER HSK 50-A

hardened and balanced, for automatic tool clamping

Standardmäßig mit dem patentierten ZETA-Sicherheitssystem ausgestattet.

Includes the patented Zeta-safety clamping system.

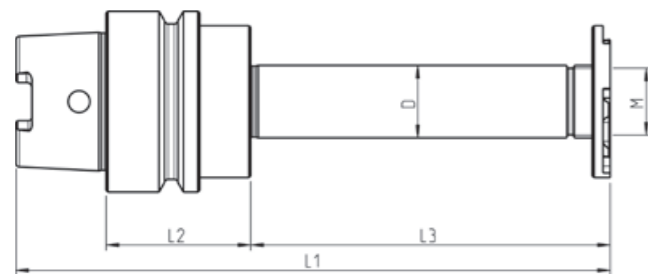

Typ / Type	D	L1	L2	L3	M	Artikelnummer Part number
Saacke	20	128	58	45	M20x1,0	SDSAA50A05804520
	20	125	40	60	M20x1,0	SDSAA50A04006020
	20	140	40	75	M20x1,0	SDSAA50A04007520
	20	165	40	100	M20x1,0	SDSAA50A04010020

Lieferumfang: Spannscheibe und dazugehöriger Ringsatz

Delivery conditions: including nut and spacer set

SAACKE / VOLLMER

Kombischleifdorne / Combined grinding wheel holder

HSK 50-A / automatisches Spannen / automatic tool clamping



SAACKE/VOLLMER-KOMBISCHLEIFDORN MIT HOHLSCHAFTKEGEL HSK 50-A

gehärtet und feingewuchtet, für automatischen Werkzeugwechsel

SAACKE/VOLLMER-COMBI GRINDING WHEEL HOLDER HSK 50-A

hardened and balanced, for automatic tool clamping

Standardmäßig mit dem patentierten ZETA-Sicherheitssystem ausgestattet.

Includes the patented Zeta-safety clamping system.

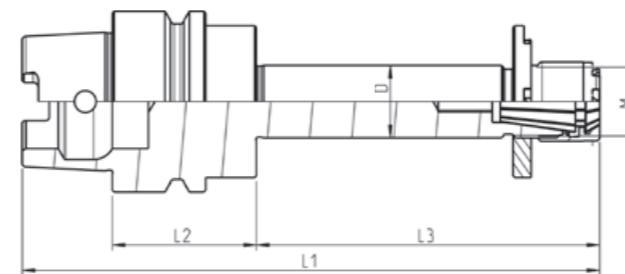

Typ / Type	D	L1	L2	L3	M	Artikelnummer Part number
Saacke	20	130	40	65	M20x1,0	SD-SPZSAA50A04006520

Lieferumfang: Spannscheibe und dazugehöriger Ringsatz

Delivery conditions: including nut and spacer set

SCHNEEBERGER

Schleifdorne / Grinding wheel holder

HSK 50-A / manuelles Spannen / manual tool clamping

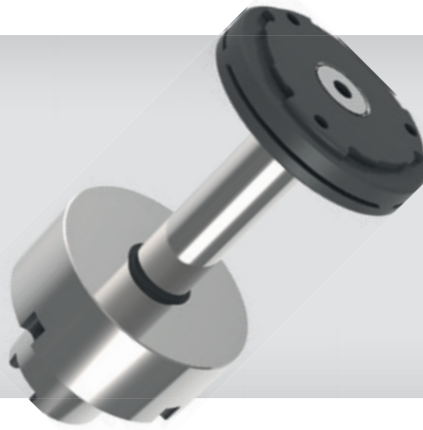

SCHNEEBERGER-SCHLEIFDORN MIT HOHLSCHAFTKEGEL HSK 50-A

gehärtet und feingewuchtet, für manuellen Werkzeugwechsel

SCHNEEBERGER-GRINDING WHEEL HOLDER HSK 50-A

hardened and balanced, for manual tool clamping

Standardmäßig mit dem patentierten ZETA-Sicherheitssystem ausgestattet.

Includes the patented Zeta-safety clamping system.

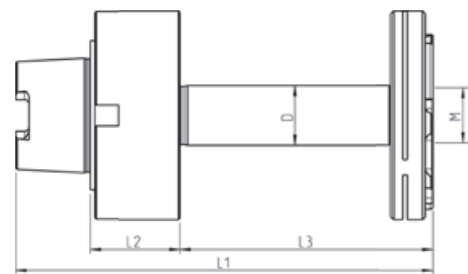

Typ / Type	D	L1	L2	L3	M	Artikelnummer Part number
Schneberger	20	100	30	45	M20x1,0	SDSCHNE50A03004520
	20	140	30	85	M20x1,0	SDSCHNE50A03008520
	20	205	30	150	M20x1,0	SDSCHNE50A03015020

Lieferumfang: Spannscheibe und dazugehöriger Ringsatz

Delivery conditions: including nut and spacer set

SCHNEEBERGER

Kombischleifdorne / Combined grinding wheel holder

HSK 50-A / manuelles Spannen / manual tool clamping

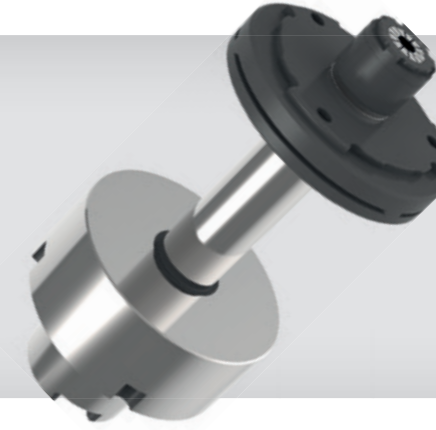

SCHNEEBERGER-KOMBISCHLEIFDORN MIT HOHLSCHAFTKEGEL HSK 50-A

gehärtet und feingewuchtet, für manuellen Werkzeugwechsel

SCHNEEBERGER-COMBI GRINDING WHEEL HOLDER HSK 50-A

hardened and balanced, for manual tool clamping

Standardmäßig mit dem patentierten ZETA-Sicherheitssystem ausgestattet.

Includes the patented Zeta-safety clamping system.

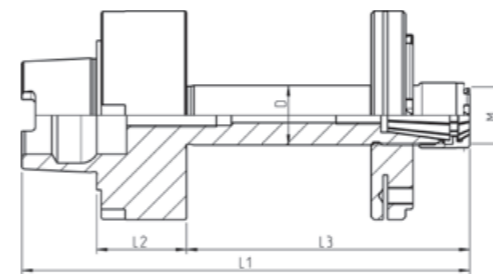

Typ / Type	D	L1	L2	L3	M	Artikelnummer Part number
Schneberger	20	120	30	65	M20x1,0	SD-SPZSCHNE50A0306520

Lieferumfang: Spannscheibe und dazugehöriger Ringsatz

Delivery conditions: including nut and spacer set

SCHNEEBERGER

Schleifdorne | Grinding wheel holder

HSK 50-A / automatisches Spannen | automatic tool clamping



ZETA-SICHERHEITSSPANNSYSTEME FÜR SCHLEIFDORNE

ZETA-SAFETY CLAMPING SYSTEMS FOR GRINDING WHEEL HOLDERS

SCHNEEBERGER-SCHLEIFDORN MIT HOHLSCHAFTKEGEL HSK 50-A

gehärtet und feingewuchtet, für automatischen Werkzeugwechsel

SCHNEEBERGER-GRINDING WHEEL HOLDER HSK 50-A

hardened and balanced, for automatic tool clamping

Standardmäßig mit dem patentierten **ZETA-Sicherheitssystem** ausgestattet.

Includes the patented Zeta-safety clamping system.

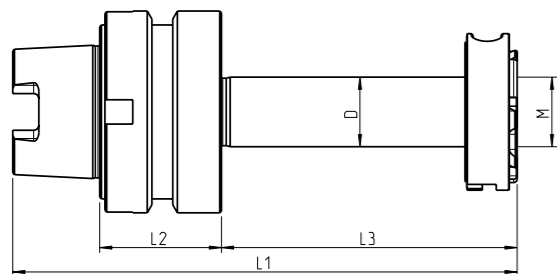

Typ / Type	D	L1	L2	L3	M	Artikelnummer Part number
Schneberger	20	145	35	85	M20x1,0	SDSCHNEA03508520
	20	205	35	150	M20x1,0	SDSCHNEA03515020

Lieferumfang: Spannscheibe und dazugehöriger Ringsatz

Delivery conditions: including nut and spacer set

Die patentierten Zeta Sicherheitssysteme bieten Ihnen enorme **Vorteile** gegenüber allen gängigen Spannsystemen. Weitere Informationen entnehmen Sie unserem **Produktkatalog**.

The patented Zeta collet clamping system provides enormous advantages over current systems. You will find more detailed information about this in our product catalog.

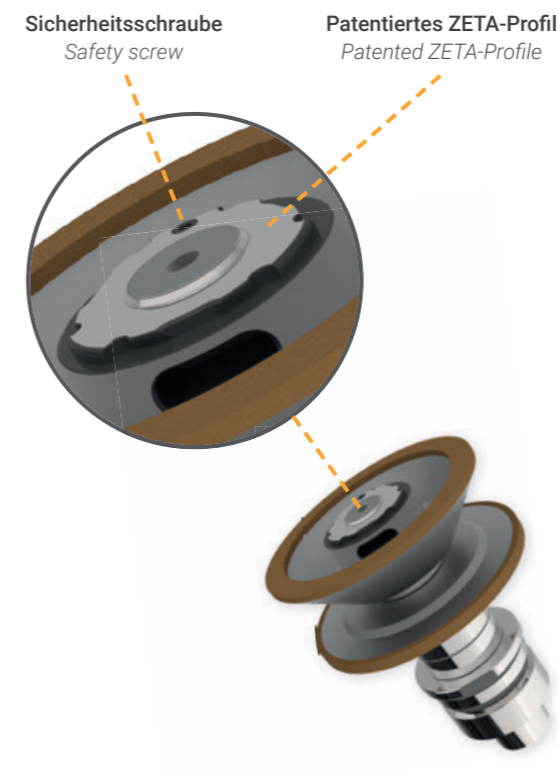

VORTEILE | ADVANTAGES

- 1** Einsetzbar von ER8 bis ER50 (DIN 6499) und OZ25 (DIN 6388)
Applicable from ER8 to ER50 (DIN 6499) and OZ25 (DIN 6388)
- 2** Stark erhöhte Spannkraft gegenüber herkömmlicher Systeme.
Improved clamping forces over current systems.
- 3** Einfaches und schnelles spannen.
Easy and fast to clamp.
- 4** Keine Verletzungsgefahr durch abrutschsicheres Spannsystem!
Prevents injury due to unique clamping properties.
- 5** Definiertes Anzugsmoment beim Einsatz eines Drehmomentschlüssels.
More accurate clamping forces with use of torque wrench.

SCHÜTTE

Schleifdorne / Grinding wheel holder

HSK 50-E / automatisches Spannen | automatic tool clamping

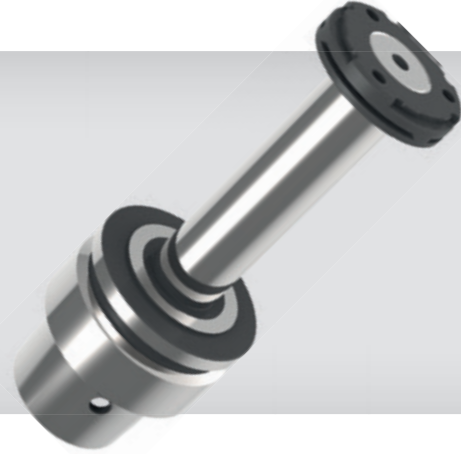

SCHÜTTE-SCHLEIFDORN MIT HOHLSCHAFTKEGEL HSK 50-E

gehärtet und feingewuchtet, für automatischen Werkzeugwechsel

SCHÜTTE-GRINDING WHEEL HOLDER HSK 50-E

hardened and balanced, for automatic tool clamping

Standardmäßig mit dem patentierten **ZETA-Sicherheitssystem** ausgestattet.

Includes the patented Zeta-safety clamping system.

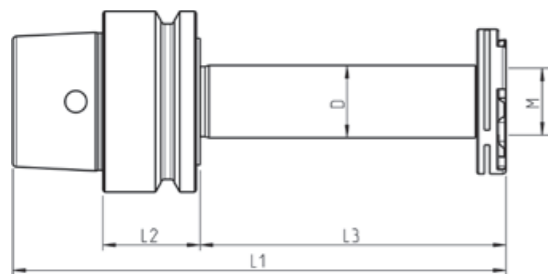

Typ / Type	D	L1	L2	L3	M	Artikelnummer Part number
Schütte	20	75	27	23	M20x1,0	SDSCHU50E027023020
	20	107	27	55	M20x1,0	SDSCHU50E027055020
	20	137	27	85	M20x1,0	SDSCHU50E027085020

Lieferumfang: Spannscheibe und dazugehöriger Ringsatz

Delivery conditions: including nut and spacer set

SCHÜTTE

Kombischleifdorne / Combined grinding wheel holder

HSK 50-E / automatisches Spannen | automatic tool clamping



SCHÜTTE-KOMBISCHLEIFDORN MIT HOHLSCHAFTKEGEL HSK 50-E

gehärtet und feingewuchtet, für automatischen Werkzeugwechsel

SCHÜTTE-COMBI GRINDING WHEEL HOLDER HSK 50-E

hardened and balanced, for automatic tool clamping

Standardmäßig mit dem patentierten **ZETA-Sicherheitssystem** ausgestattet.

Includes the patented Zeta-safety clamping system.

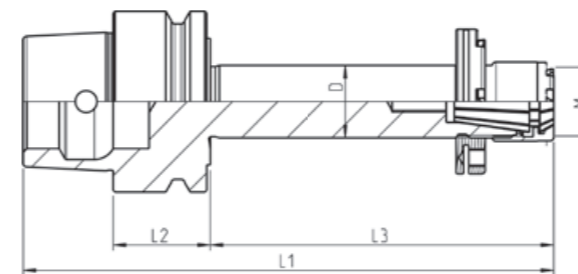

Typ / Type	D	L1	L2	L3	M	Artikelnummer Part number
Schütte	20	117	27	65	M20x1,0	SPZ-SDSCHU50E027065020

Lieferumfang: Spannscheibe und dazugehöriger Ringsatz

Delivery conditions: including nut and spacer set

TTB

Schleifdorne | Grinding wheel holder

HSK 32-C



TTB-SCHLEIFDORNE MIT HOHLSCHAFTKEGEL HSK 32-C

Für TTB Maschinen, gehärtet und feingewuchtet

TTB-GRINDING WHEEL HOLDER HSK 32-C

For TTB-machines, hardened and balanced

Standardmäßig mit dem patentierten **ZETA-Sicherheitssystem** ausgestattet.

Includes the patented Zeta-safety clamping system.

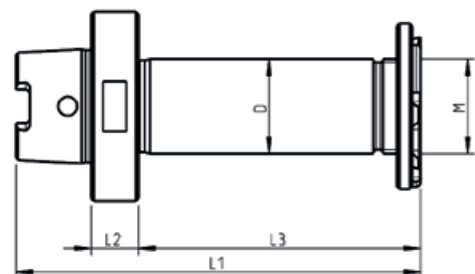

Typ / Type	D	L1	L2	L3	M	Artikelnummer Part number
TTB	20	52	10	26	M20x1,0	TBTTB32C01001620
	20	68	10	42	M20x1,0	TBTTB32C01003220
	20	86	10	60	M20x1,0	TBTTB32C01005020

Lieferumfang: Spannscheibe und dazugehöriger Ringsatz

Delivery conditions: including nut and spacer set

WALTER

Schleifdorne | Grinding wheel holder

manuelles Spannen | manual tool clamping



WALTER-SCHLEIFDORN

gehärtet und feingewuchtet, für manuellen Werkzeugwechsel

WALTER-GRINDING WHEEL HOLDER

hardened and balanced, for manual tool clamping

Standardmäßig mit dem patentierten **ZETA-Sicherheitssystem** ausgestattet.

Includes the patented Zeta-safety clamping system.

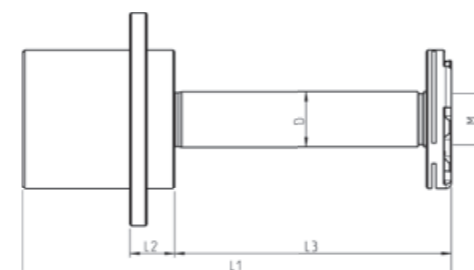

Typ / Type	D	L1	L2	L3	M	Artikelnummer Part number
Walter	20	95	16,15	40	M20x1,0	SDWALT016040020
	20	115	16,15	60	M20x1,0	SDWALT016060020
	20	155	16,15	100	M20x1,0	SDWALT016010020

Lieferumfang: Spannscheibe und dazugehöriger Ringsatz

Delivery conditions: including nut and spacer set

WALTER

Schleifdorne | Grinding wheel holder

HSK 40-A / Standard- & gestufter Schaft | standard- & stepped shaft



WALTER-SCHLEIFDORN MIT HOHLSCHAFTSKEGEL HSK 40-A

gehärtet und feingewuchtet, für manuellen Werkzeugwechsel

WALTER-GRINDING WHEEL HOLDER HSK 40-A

hardened and balanced, for manual tool clamping

Standardmäßig mit dem patentierten ZETA-Sicherheitssystem ausgestattet.

Includes the patented Zeta-safety clamping system.

Walter HSK40A: standard-Schaft

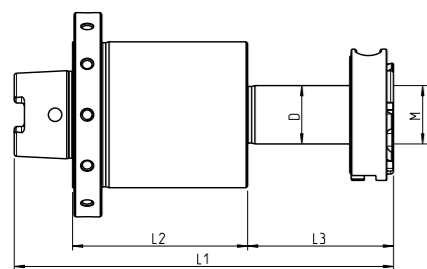

Walter HSK40A: gestufter Schaft

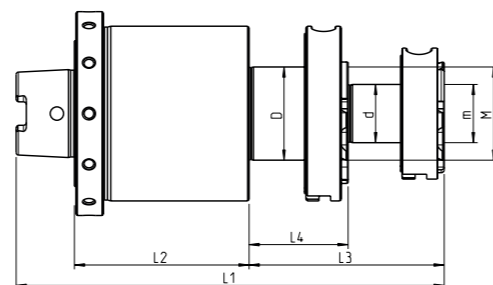

Typ / Type	D	d	L1	L2	L3	L4	M	m	Artikelnummer Part number
Walter	20	x	125	60	45	x	M20x1,0	x	SDWALT40A06005020
	20	x	152	80	52	x	M20x1,0	x	SDWALT40A08005220
	32	x	122	60	42	x	M30x1,0	x	SDWALT40A06004232
	31,75	x	125	60	45	x	M30x1,0	x	SDWALT40A06004531.75
gestufter Schaft	32	20	147	60	67	33	M32x1,0	M20x1,0	SDWALT40A0600673203320

Lieferumfang: Spannscheibe und dazugehöriger Ringsatz

Delivery conditions: including nut and spacer set

WALTER

Schleifdorne | Grinding wheel holder

HSK 50-A / automatisches Spannen | automatic tool clamping



WALTER-SCHLEIFDORN MIT HOHLSCHAFTKEGEL HSK 50-A

gehärtet und feingewuchtet, für automatischen Werkzeugwechsel

WALTER-GRINDING WHEEL HOLDER HSK 50-A

hardened and balanced, for automatic tool clamping

Standardmäßig mit dem patentierten ZETA-Sicherheitssystem ausgestattet.

Includes the patented Zeta-safety clamping system.

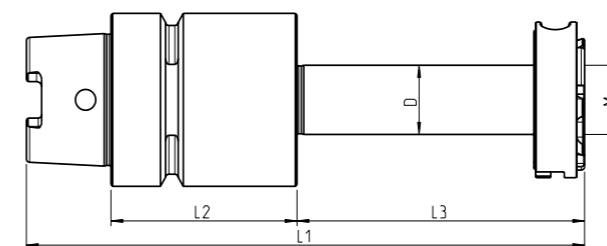

Typ / Type	D	L1	L2	L3	M	Artikelnummer Part number
Walter	20	120	55	40	M20x1,0	SDWALT50A05504020
	20	140	55	60	M20x1,0	SDWALT50A05506020
	20	165	55	85	M20x1,0	SDWALT50A05508520
	20	180	55	100	M20x1,0	SDWALT50A05510020

Lieferumfang: Spannscheibe und dazugehöriger Ringsatz

Delivery conditions: including nut and spacer set

CONDITIONS OF SALE

DELIVERY

Shipping dates are approximate and are based upon prompt receipt of all necessary information. The Company shall not be liable for delays in delivery or failure to manufacturer of delivery (1) due to causes beyond its reasonable control, or (2) due to acts of God, acts of the Purchaser, acts of civil or military authorities, priorities, fires, strikes, floods, epidemics, war, riot, delays in transportation or car shortages, or (3) inability due to causes beyond its reasonable control to obtain necessary labor, materials, components or manufacturing facilities. In the event of any such delay, the date of delivery shall be extended for a period equal to the time lost by reason of the delay.

In all cases, risk or damage to goods in transit shall fall upon the Purchaser, whose responsibility it shall be to file claims with the carrier.

PAYMENTS

Each shipment shall be considered a separate and independent transaction, and payment therefore shall be made accordingly. If shipments are delayed by the Purchaser, payments shall become due on the date when the Company is prepared to make shipment. If the work to be performed hereunder is delayed by the Purchaser, payments shall be made based on the purchase price and the percentage of completion. Products held for the Purchaser shall be at the risk and expense of the Purchaser if the financial condition of the Purchaser at any time does not, in the judgment of the Company, justify continuance of the work to be performed by the Company hereunder on the terms of the payment as agreed upon, the Company may require full or partial payment in advance or shall be entitled to cancel any order then outstanding and shall receive reimbursement for its reasonable and proper cancellation charges, and in the event of bankruptcy or insolvency of the purchaser or in the event any proceeding is brought against the Purchaser, voluntary or involuntary under the bankruptcy or any insolvency laws, the Company shall be entitled to cancel any order then outstanding at any time during the period allowed for filling claims against the estate and shall receive reimbursement for its reasonable and proper cancellation charges. All invoices are due and payable not later than 30 days from date of invoice unless specific terms have been agreed to or granted. Orders may be prepaid by either MASTERCARD or VISA credit cards. Sales and Similar Taxes Unless otherwise stated herein, the Company's prices do not include sales, use, excise or similar taxes. Consequently, in addition to the price specified herein, the amount of any present of future sales, use excise or other similar tax applicable to the sale or use of the equipment hereunder shall be paid by the Purchaser, or in lieu thereof the Purchaser shall provide the Company with a tax-exemption certificate acceptable to the taxing authorities.

CANCELLATIONS AND RETURNS

The Purchaser may cancel his order only upon written notice and upon payment to the Company of the reasonable and proper cancellation charges. No returns will be accepted after 30 days from the date of receipt of goods. Cancellation charges are 15% of the order value on standard products and no cancellation will be accepted on special orders, these would include tooling that has been laser marked with purchaser's company name or logo.

LIMITATION OF LIABILITY

The Company's liability on any claim of any kind, including negligence, for any loss or damage arising out of, connected with, or resulting from this contract, or from the performance of breach therefore, or from the manufacture, sale, delivery, resale, repair or use of any product covered by or furnished under this contract shall in no case exceed the price allocable to the product covered by or furnished under this contract nor exceed the price allocable to the product or part thereof which gives rise the claim, In no event shall the Company be liable for special or consequential damages.

SECURITY TITLE

Title and right of possession of the products sold hereunder shall remain with the Company and such products shall remain per sonal property until all payments hereunder (including deferred payments whether evidenced by notes or otherwise) shall have been made in full in each, and the Purchaser agrees to do all acts necessary to perfect and maintain such right and title in the Company.

GENERAL

The product sold hereunder was not designed or manufactured for use in or with any atomic installation or activity. If so used, the Company disclaims all responsibility of every kind, including negligence, and in addition the Purchaser shall indemnify and hold the Company harmless for any liability or damage whatsoever arising out of the use of the product in such a manner.

PRICING

The prices are subject to a change with a 3 month notice. All orders will be furnished at prices in effect at the time of order. Delivery TermsAll prices are F.O.B. including any handling or packing charges if applicable.

NOTIZEN NOTES

SCHLEIFAUFNAHMEN SIND FÜR FOLGENDE HERSTELLER VERFÜGBAR:
GRINDING WHEEL HOLDER ARE AVAILABLE FOR FOLLOWING BRANDS:



Anca • Haas
Hawema • Saacke
Deckel/Isog • Schneeberger
Rollomatic • Schütte
Reinecker • Walter